

# Unit 04

## Logic Gates

**01.2011 A/L**

Which of the following would be the result if the Boolean expression  $F(x,y)=\overline{(x+y)}.\overline{(x+y)}$  is simplified by using De Morgan's law?

- (1)  $x$                       (2)  $y$                       (3)  $0$                       (4)  $1$                       (5)  $x,y$

**02.** Which of the following Boolean expressions represents the given logic circuit?

- (1)  $\overline{(A+B)} + (B+C)$                       (2)  $(A+B) + (B.C)$   
 (3)  $\overline{(A+B)} + \overline{(B+C)}$                       (4)  $\overline{(A.B)} + (B.C)$   
 (5)  $\overline{(A+B)} + (B.C)$

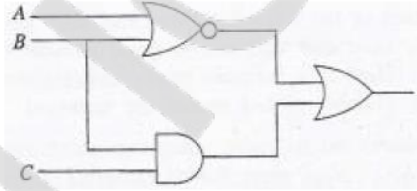

**03. 2012 A/L**

What would be the result if the following Boolean expression is simplified?

$$F(x,y)=\overline{x}\overline{y}(\overline{x+y})(y+\overline{y})$$

- (1)  $\overline{x}$                       (2)  $\overline{y}$                       (3)  $x$                       (4)  $y$                       (5)  $xy$

**04.** Which of the following Boolean expression represents the output of the given logic circuit?

- (1)  $\overline{(A+B)} + \overline{(B.C)}$   
 (2)  $\overline{(A+B)} . \overline{(B.C)}$   
 (3)  $\overline{(A+B)} . (B.C)$   
 (4)  $\overline{(A.B)} + \overline{(B.C)}$   
 (5)  $\overline{(A.B)} + (B+C)$

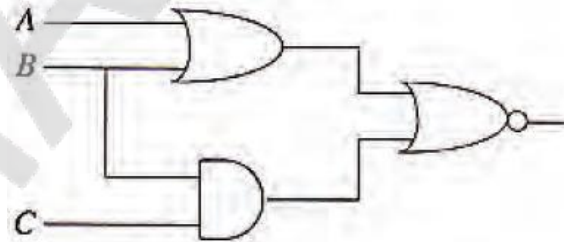

**05.2013 A/L**

The Boolean expression  $(x+y) . (x+z)$  simplified to .....

- (1)  $x$                       (2)  $x . (y+z)$                       (3)  $x . y . z$                       (4)  $x + y . z$                       (5)  $x + y + z$

**06.** Which of the following Boolean expressions represents the output (Q) of the circuit shown below?

A and B are inputs.

- (1)  $A'.B' + A.B'$   
 (2)  $A'.B' + A.B$   
 (3)  $A.B + A'.B'$   
 (4)  $A'.B + A.B'$   
 (5)  $A'.B + A'.B'$

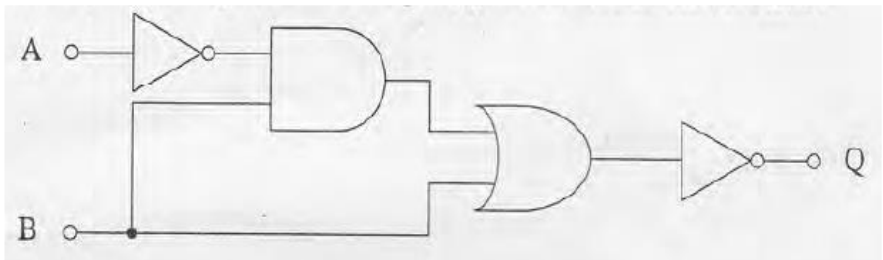

07. Which of the following is an **incorrect** Karnaugh Map layout to represent a Boolean function of four (4) Boolean variables a, b, c and d?

(1)

ab\cd	01	00	10	11
01				
00				
10				
11				

(2)

ab\cd	01	00	10	11
01				
00				
10				
11				

(3)

ab\cd	01	00	11	10
01				
00				
11				
10				

(4)

ab\cd	11	10	00	01
11				
10				
00				
01				

(5)

ab\cd	00	10	11	01
00				
10				
11				
01				

08. 2014 A/L

Consider the following logic circuit:

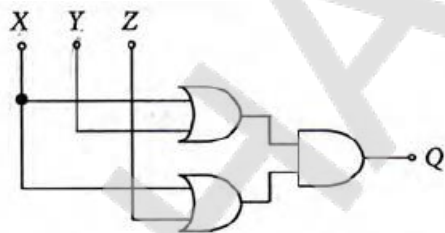

Which of the following circuit diagrams represents a simplified version of the above circuit?

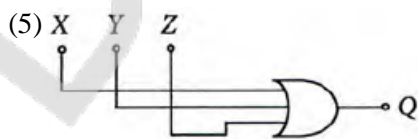
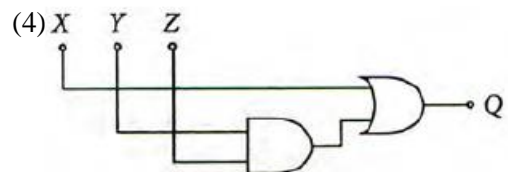
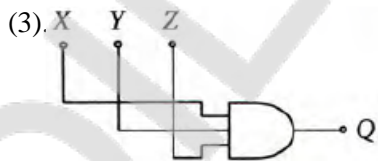
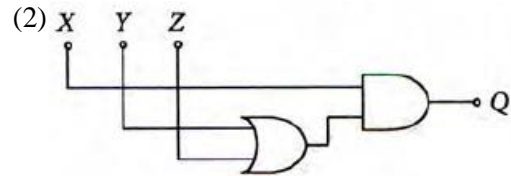
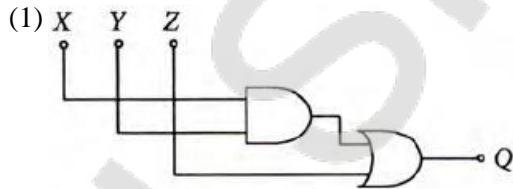

09. Consider the following circuit with four push button switches namely: S1, S2, S3, and S4. These four switches can either be in pushed or released states which are represented by 1 and 0 respectively. (Note: In the circuit given below, all the switches are in released state having value 0).

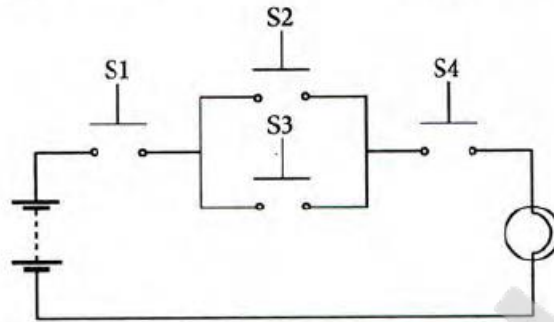

Which of the following Boolean expressions represents the function of the bulb, if the on state of the bulb is represented by the value 1?

- (1)  $S1 + (S2 \cdot S3) + S4$       (2)  $(S1 + S2) \cdot (S3 + S4)$       (3)  $(S1 \cdot S2) + (S3 \cdot S4)$   
 (4)  $S1 \cdot S4 \cdot (S2 + S3)$       (5)  $S2 + (S1 \cdot S4) + S3$

**10. 2015 A/L**

Consider the following combinatory circuit implemented using universal gates:

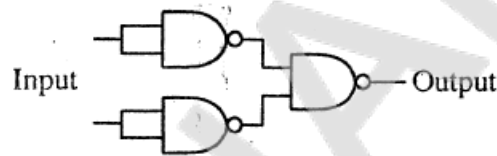

The above circuit is equivalent to a/an

- (1) AND Gate      (2) OR Gate      (3) NAND Gate      (4) NOR Gate      (5) NOT Gate

**11. 2016 A/L**

Consider the following logic circuit implemented using universal gates:

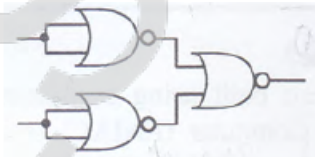

The above circuit is equivalent to a/an

- (1) NOT Gate      (2) AND Gate      (3) OR Gate      (4) NAND Gate      (5) NOR Gate

**12. 2018 A/L**

Consider the following Boolean expression.

$$\overline{A + B \cdot \bar{C}}$$

Which of the following is/are equivalent to the above expression?

- I.  $\bar{A} + \bar{B} \cdot C$   
 II.  $\bar{A} \cdot B \cdot \bar{C}$   
 III.  $\bar{A} \cdot \bar{B} + \bar{A} \cdot C$

- (1) I only      (2) II only      (3) III only      (4) I and II only      (5) II and III only

13. Consider the following logic circuit.

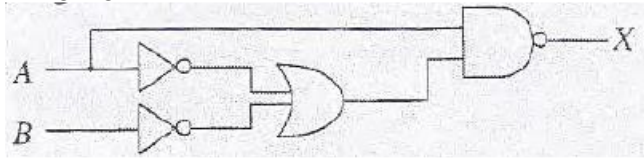

Which of the following circuit/s is/are equivalent to the above circuit?

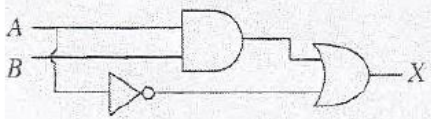

I

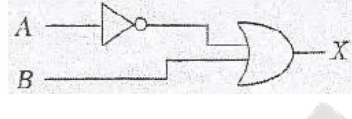

II

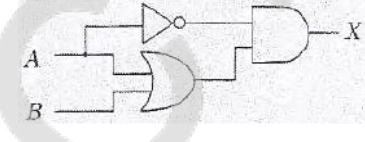

III

- (1) I only      (2) II only      (3) III only      (4) I and II only      (5) All I, II and III

14. 2019 A/L

Consider the following logic circuit diagram to answer the questions.

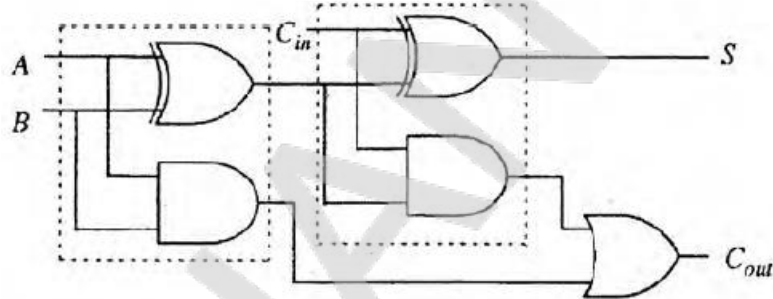

- Which of the following statements is/are correct about the above circuit?
  - I – It implements a full adder.
  - II – The logic function of S can be started as  $S = A \oplus B \oplus C_{in}$
  - III – The logic function of  $C_{out}$  can be started as  $C_{out} = AB + BC_{in} + AC_{in}$

- (1) I only      (2) II only      (3) I and II only      (4) II and III only      (5) All I, II and III

15. Consider the Karnaugh map shown below:

		AB			
		00	01	11	10
C	0	0	0	0	1
	1	1	1	0	1

Which of the following is the correct logic expression that corresponds to the two marked segments on the Karnaugh map?

- (1)  $A\bar{B} + B\bar{C}$       (2)  $\bar{A}\bar{C} + AB$       (3)  $(\bar{A} + \bar{C})(A + B)$   
 (4)  $(A + C)(\bar{A} + \bar{B})$       (5)  $AC + \bar{A}\bar{B}$

16.2020 A/L

Which of the following is the most simplified expression to  $A\bar{B}\bar{C} + B\bar{C} + \bar{A}BC + BC$ ?

- (1)  $A\bar{B}\bar{C} + \bar{A}BC + B$       (2)  $\bar{B}(A\bar{C} + \bar{A}C) + B$       (3)  $\bar{C}(A\bar{B} + B) + C(\bar{A}\bar{B} + B)$   
 (4)  $\bar{A}\bar{C} + B$       (5)  $A\bar{C} + \bar{A}C + B$

17. A block diagram of sequential logic circuit is shown below, with one block labelled as “A” and the other labelled as “B”.

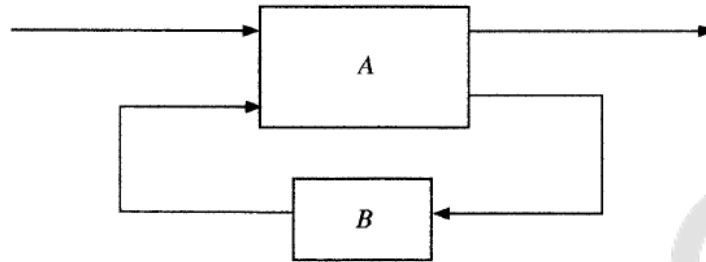

Which of the following statements about the above block diagram are correct?

- I – The block A is a combinational logic circuit.
- II – The block B is a memory element.
- III – Only the block A can be implemented using logic gates.

- (1) Only I      (2) Only II      (3) Only I and II      (4) Only I and III      (5) All I, II and III

18. Consider the following logic circuit consisting of NAND gates:

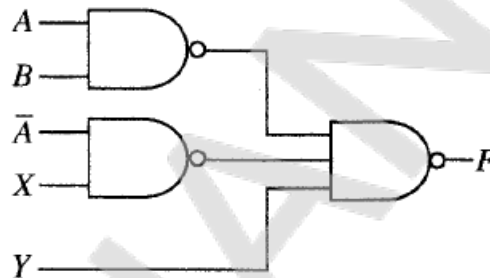

If the required output of the above circuit is  $AB + \bar{A}\bar{B} + \bar{C}$  then what should the inputs X and Y be?

- (1)  $X=B$  and  $Y=C$       (2)  $X=B$  and  $Y=\bar{C}$       (3)  $X=\bar{B}$  and  $Y=C$   
 (4)  $X=\bar{B}$  and  $Y=\bar{C}$       (5)  $X=\bar{C}$  and  $Y=B$

19. 2021 A/L

Consider the following Karnaugh map and the logic circuit implemented based on it where A, B and C are the inputs and Z is the output:

		AB			
		00	01	11	10
C	0	0	e	f	0
	1	1	g	h	1

(a) Karnaugh Map

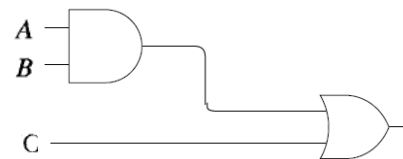

(b) Logic circuits based on Karnaugh Map

For the Logic Circuit to correctly implement the logic function represented in the Karnaugh map, what should be the values of e, f, g, h?

- (1) e=0, f=0, g=1, h=1      (2) e=0, f=1, g=1, h=1  
 (3) e=1, f=0, g=1, h=1      (4) e=1, f=1, g=0, h=0  
 (5) e=1, f=1, g=0, h=1

20. 2022 A/L

Consider the following logic circuit:

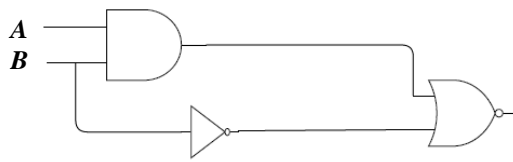

When  $B=1$ , what would **definitely** be the output at  $Q$ ?

- (1)  $A$             (2)  $\bar{A}$             (3)  $B$             (4)  $\bar{B}$             (5)  $0$

21. Simplified Boolean expressions help to obtain simpler circuits.

Which of the following is a simplified form of  $X + \bar{X}Y$  ?

- (1)  $X$             (2)  $Y$             (3)  $XY$             (4)  $\bar{X}Y$             (5)  $X + Y$

22. Consider the following truth table:

A	B	C	Z
0	0	0	0
0	0	1	0
0	1	0	1
0	1	1	1
1	0	0	1
1	0	1	1
1	1	0	0
1	1	1	0

What is the correct Karnaugh map for the above truth table?

(1) 

$A \backslash BC$	00	01	10	11
0	0	0	1	1
1	1	1	0	0

(2) 

$A \backslash BC$	00	01	11	10
0	0	0	1	1
1	1	1	0	0

(3) 

$A \backslash BC$	00	10	01	11
0	0	1	0	1
1	1	0	1	0

(4) 

$A \backslash BC$	00	10	11	01
0	0	1	1	0
1	1	0	0	1

(5) 

$A \backslash BC$	00	11	10	01
0	0	1	1	0
1	1	0	0	1

23. 2023 A/L

Consider the following logic circuit in which X indicates a two-input logic gate.

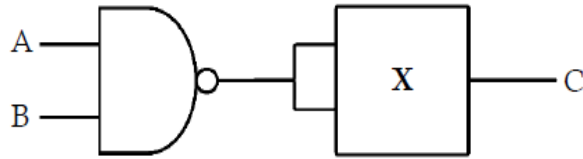

Which of the following should X be so that when  $A = 0$  and  $B = 1$ , the output C would be 0 ?

I – a NAND gate

II – a NOR gate

III – an XOR gate

(1) I only

(2) I and II only

(3) I and III only

(4) II and III only

(5) All I,II and III

24. Which of the following is the simplified form of the Boolean expression  $X(\bar{X} + Y)$  ?

(1) X

(2) Y

(3) XY

(4)  $\bar{X}Y$

(5)  $X + Y$